

(No Model.)

2 Sheets—Sheet 1.

A. E. SHATTUCK.
ADDING MACHINE.

No. 453,778.

Patented June 9, 1891.

Fig. 1.

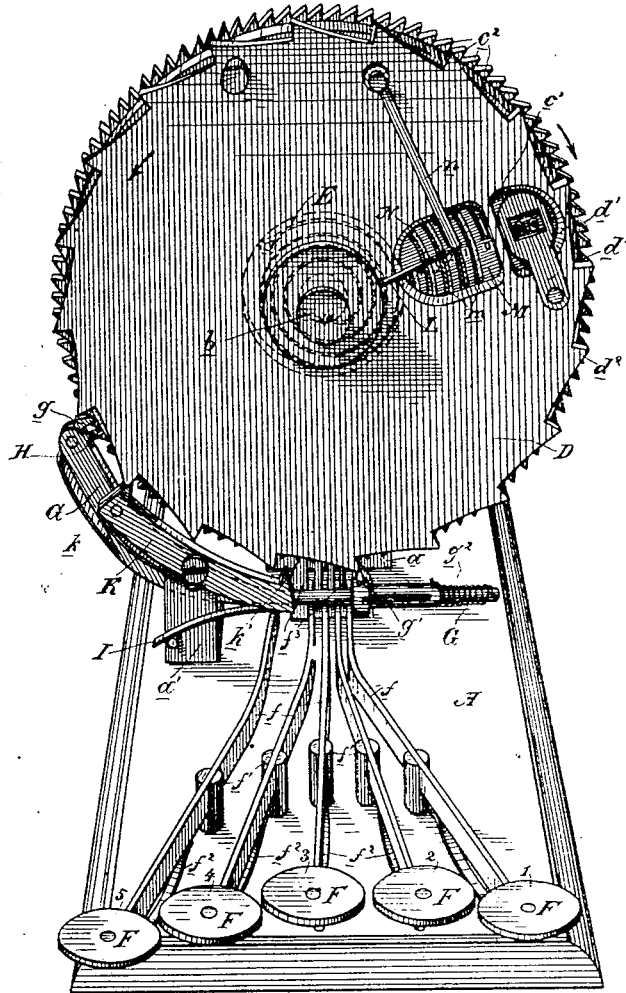

Witnesses,
J. H. Morse,
J. W. Fowler.

Inventor,
Arthur E. Shattuck,
By Dewey & Co
attys

(No Model.)

2 Sheets—Sheet 2.

A. E. SHATTUCK.
ADDING MACHINE.

No. 453,778.

Patented June 9, 1891.

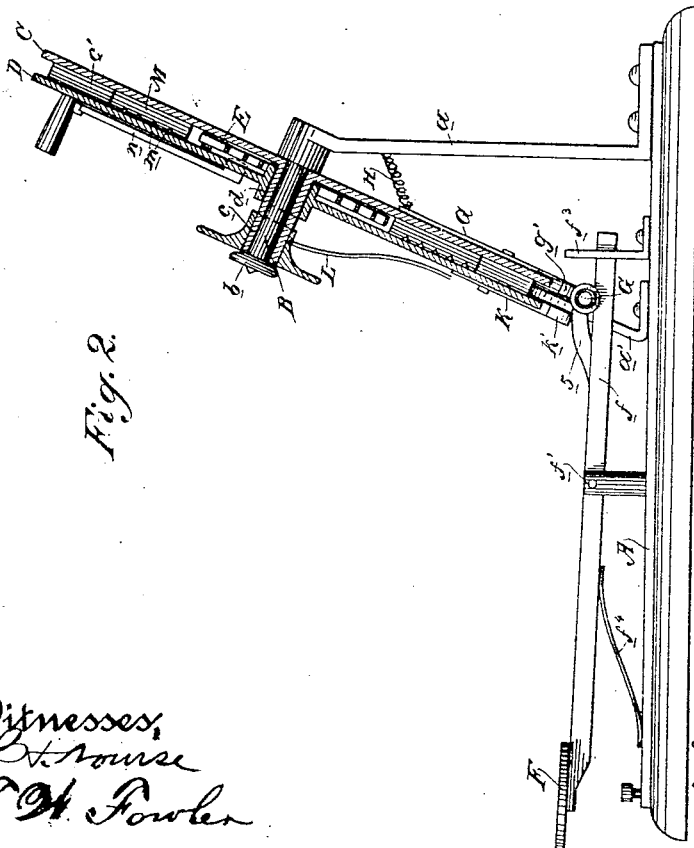
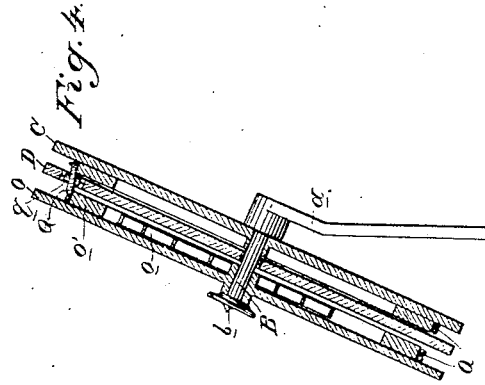
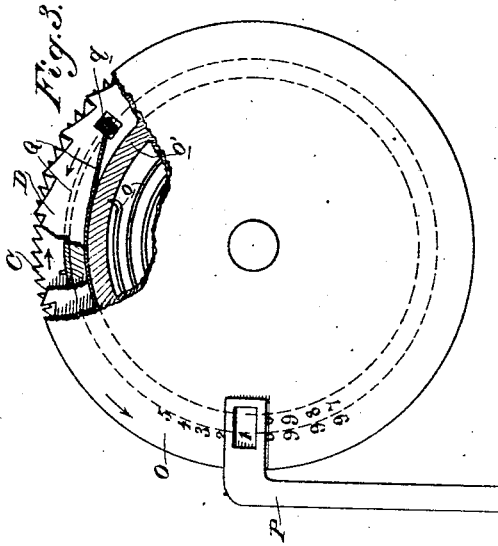

Witnesses,
J. H. Fowler

Inventor,
Arthur E. Shattuck
Dewey Co.,
Patro

BEST AVAILABLE COPY

UNITED STATES PATENT OFFICE.

ARTHUR E. SHATTUCK, OF SAN FRANCISCO, CALIFORNIA.

ADDING-MACHINE.

SPECIFICATION forming part of Letters Patent No. 453,778, dated June 9, 1891.

Application filed July 29, 1890. Serial No. 360,319. (No model.)

To all whom it may concern:

Be it known that I, ARTHUR E. SHATTUCK, a citizen of the United States, residing in the city and county of San Francisco, State of California, have invented an Improvement in Adding-Machines; and I hereby declare the following to be a full, clear, and exact description of the same.

My invention relates to the general class of adding-machines, and especially to that subclass in which the spring-actuated plate or plates are controlled by means of a pawl and ratchet operated by keys.

My invention consists, essentially, in oppositely-moving plates, one moving varying distances and the other a given distance, as a result of which combinations may be made of the first four digits with the fifth to obtain all the digits.

My invention also consists in the novel construction and arrangement of parts herein-after fully described, and specifically pointed out in the claims.

The general object of my invention is to materially simplify the construction and operation of this class of adding-machines, whereby greater rapidity and accuracy are attained.

Referring to the accompanying drawings for a more complete explanation of my invention, Figure 1 is a front view of my machine. Fig. 2 is a vertical section of the plates C and D and a side elevation of the key portion. Fig. 3 is a front view of a supplementary plate O of a modified form of machine, a portion of said plate being broken away to show the back plates. Fig. 4 is a section of the three plates of said modified form.

A is the bed-plate, having rising from its rear end a standard *a*, which carries in its top a supporting spindle or shaft B.

C is a plate, here shown in the form of a disk and having a tubular hub *c*, whereby it is mounted and adapted to turn on the spindle B. Upon the face of this plate are delineated the numbers, say, from 1 to 99, inclusive, with a starting cipher or point between them, as they are here arranged in annular series. These numbers, though they may be made on the face of the disk, are preferably made upon a separate ring *c'*, secured to said disk.

D is a second plate, having a tubular hub

d, whereby it is fitted and adapted to turn upon the tubular hub *c* of plate C. A small screw *b* in the end of the spindle B holds both plates to place. In the rim of plate D is a sight-aperture *d'*, through which the numbers on plate C may be seen, and in this aperture, for greater accuracy in reading, is an apertured pointer *d''*, which covers up all but one number.

A spring E lies between the two plates C and D, an end being connected with each, whereby it turns the plates in opposite directions. It will be well at this point to describe the use of these parts, so that a knowledge of the principle of operation of the machine being gained, the subsequent description of constructions will be better understood.

Facing the machine, the plate C may turn to the right and the plate D to the left. Now if plate C be turned the minimum distance it will exhibit through the sight-aperture a number increased by one; if turned twice the distance, it will show a number increased by two; if turned three times the distance, it will show a number increased by three, and if turned four times the distance it will show a number increased by four. This is true considering the plate D as being at rest. Now consider the plate C at rest, and that we turn the plate D in the direction opposite to the direction in which the plate C turns, and that it turns through a distance equal to five numbers. It is then evident that in the now changed position of the sight-aperture *d'* it will exhibit a number through it, increased by five over the number seen through it before it made its change. We have therefore provided for adding digits up to five. Now as the plates are independent and can move simultaneously in opposite directions, we can add six by turning the plate C its minimum distance of one and turning plate D its given distance of five, for the one is gained by the movement of plate C to the right and the five is had by the movement of plate D to the left. So, also, we can add seven by turning plate C a distance of two and plate D its distance of five. Thus, also, we can add eight and nine, and it will be seen that these combinations of the first four digits with the fifth give us all the digits, and also that these combinations can be effected as rapidly as the single elements.

The mechanism for operating the plates is

as follows: F are five keys, numbered, consecutively, 1, 2, 3, 4, and 5. Their levers f are pivoted at f' , and springs f^2 control them. The levers of keys 1, 2, 3, and 4 are guided at their rear ends by a slotted guide-piece f^3 . The rim of plate C is provided with teeth c^2 , separated by the distance of one number. The rim of plate D is provided with teeth d^2 , separated by a distance of five numbers. Rising from bed A is a standard a' , to which is pivoted a pawl-carrier G, having a holding-pawl g at its upper end, which engages the teeth c^2 of plate C. A spring H holds the pawl-carrier in normal position with its pawl g to its engagement. The lower arm of pawl-carrier G passes directly over the levers of the keys 1, 2, 3, and 4, and fitted to slide upon the end of this arm by means of a guiding slot and pin is a catch-pawl g' , having a controlling-spring g^2 , by which said pawl is kept normally retracted, so that its inner end lies just beyond the lever of key 1. Now when the lever of said key is raised it comes up under and raises the lower arm of the pawl-carrier G, and so swings said carrier that the upper or holding pawl g is withdrawn from the teeth c^2 of plate C, and the lower or catch pawl is raised to engagement with said teeth and temporarily holds the plate, said pawl being limited in its sliding movement by the side of the key-lever which lies in contact with the lower portion of the body of said pawl. When the key is released, the spring H returns the pawl-carrier, so that its holding-pawl returns to engagement, and the catch-pawl is lowered and is returned by its spring. During this operation the spring E turns plate C the distance of one number. When key 2 is operated, the same operation takes place, but the plate C turns a distance of two numbers before it is held by pawl g' , which has a greater distance to slide before being limited by the lever of key 2. Likewise with keys 3 and 4, the sliding catching-pawl allowing the greater movement of the plate before being limited by the lever of the key operated. To the standard a' is also pivoted a pawl-carrier K, controlled by a spring I. In the upper end of this carrier is a holding-pawl k and at the lower end a catch-pawl k' . The former is in normal engagement with the teeth d^2 of plate D. Under the lower end of pawl-carrier K the lever of key 5 operates. Now upon operating said key so as to raise the lever it swings the pawl-carrier to release pawl k and throws into engagement pawl k' . Then upon relieving the key the spring I returns the pawl, so that its holding-pawl returns to engagement. During this operation the plate D turns under the power of spring E one tooth, which, as before described, is a distance of five numbers.

Both the pawls g and k are swinging spring-controlled ones, of common construction, catching the teeth one way and allowing them to slip in the other, so that both plates may

be turned back to wind up the spring E and to reach any initial position.

The operation is as follows: The plate D is so turned that through its aperture the ciphers are seen which mark the beginning. Given the following column to add:

3	
1	
9	75
8	
2	
7	
5	
4	80
6	

For the 6 keys 5 and 1 are pressed simultaneously, whereupon the plate C moves one number to the right and plate D moves five numbers to the left, and through the sight-aperture figure 6 is seen. Then press key 4, and plate C, moving to the right, discloses figure 10. Then press key 5, and plate D, moving to the left, brings its sight-aperture over 15. Then press simultaneously keys 5 and 2, and the plates moving oppositely disclose 22. Then press key 2, and plate C discloses 24. Then press keys 5 and 3 together, and 32 is disclosed; then keys 5 and 4, and 41 is seen; then key 1, and we see 42, and, finally, key 3, and 45 is shown as the total. Thus with but two plates I am enabled to employ but five keys and to read in totals, instead of employing a separate plate for each key and having to subsequently add the numbers shown by all the plates to reach the total.

L is a small pointer secured to a thumb-disk and mounted frictionally on the end of hub c of plate C, its use being to point to the ciphers, showing where they are and indicating the initial point.

Now as it may be inconvenient to carry the numbers above 99 without having too big a plate, I have provided as follows for indicating the hundreds: Upon the face of plate C, concentric and within the ring upon which the numbers are made, is a second ring M, and in this is made a spiral groove m , beside each round of which are numbers representing the hundreds. Thus, beside one will be figures 1, beside another figures 2, and so on. In plate D, beside the first sight-aperture, is a second sight-aperture N, and in this lies a spring-pointer n , having a sharp under edge, which bears and travels in the spiral groove m . When 100 has been reached, the pointer enters the round of the groove beside which are the figures 1, and when 200 is reached the pointer, traveling in the spiral groove, reaches the round marked 2, and so on, its springy character enabling it to bend sufficiently to follow the spiral course of the groove.

The essence of my invention resting, as before stated, in the oppositely-moving plates, the one moving to varied distances and the other to a given distance, whereby I am enabled to indicate the first five digits and make

combinations of the first four with the fifth to indicate the remaining digits, I do not confine myself to indicating or reading these digits and totals thereof, upon one plate through a sight-aperture in the other. I can use the movements of the two plates to indicate these results otherwise, as I shall now describe and illustrate by reference to Figs. 3 and 4.

10 Upon the forward end of spindle B, I mount a plate O, around the face of which I make the numbers, as shown. In this case there will be no numbers on plate C and no sight-aperture in plate D, though they will be otherwise the same as before described and having the same movements.

P is an apertured sight-piece or indicator rising from and fixed to the bed A, and through which the numbers on plate O can be seen. 20 A spring *o* behind and connected with said plate tends constantly to turn it in one direction, say—to the left. Its escapement and movement are effected by means of a string Q, which is wound several times about a flange *o'* on its inner surface, and thence said string passes under a slip-bearing or roller *q*, carried by plate D, and is then wound several times about a flange on plate C in a direction opposite to the direction in which it is wound on plate O. Now when plate C moves to the right it unwinds and pays out the string, and plate O, under the power of its spring, moves to the left, taking up the slack of the string and being limited by said string when taut, 35 thus effecting a movement equal to that of plate C, and when plate D turns to the left it acts through its bearing-roller *q* to pull off a given amount of string from plate C, thus allowing the plate O to again move to take up the slack, and its movement is equal to that of plate D. Thus the numbers pass behind a fixed sight and can always be read in the same place.

Having thus described my invention, what I claim as new, and desire to secure by Letters Patent, is—

1. In an adding-machine, movable plates from the movement of which the indications are taken, said plates being movable in opposite directions, a spring for effecting their movements, controlling mechanisms for limiting the movement of one at different distances and of the other at a given distance, and keys for operating said controlling mechanisms, substantially as herein described.

2. In an adding-machine, the combination of movable plates from the movements of which the indications are taken, said plates being movable in opposite directions, a set of separate keys and connections for effecting the movement of one of said plates to different distances, and a single key for effecting the movement of the other plate to a given distance, substantially as herein described.

3. In an adding-machine, plates movable in opposite directions, the movement of one of

said plates being to varied distances and that of the other to a given distance, a series of numbers carried by one of said plates, and a sight carried by the other, substantially as herein described.

4. In an adding-machine, superposed plates movable in opposite directions, the movement of one of said plates being to varied distances and that of the other to a given distance, the 75 under plate carrying a series of numbers and the upper plate a sight-aperture over said numbers, substantially as herein described.

5. In an adding-machine, the combination of plates movable in opposite directions, one 80 of said plates carrying a series of numbers and the other an indicating-sight, a set of separate keys and connections for effecting the movement of one of said plates to different distances, and a single key for effecting 85 the movement of the other plate to a given distance, substantially as herein described.

6. In an adding-machine, the oppositely-movable plates from the movement of which the indications are taken, the single spring 90 between them for effecting their movements, controlling mechanisms for limiting the movement of one at different distances and of the other at a given distance, and keys for operating said controlling mechanisms, substantially 95 as herein described.

7. In an adding-machine, the combination of the rotatory spring-actuated plate C, having teeth upon its rim, the separate keys and key-levers, the pivoted spring-controlled pawl-carrier operated by the key-levers, the holding-pawl thereof, and the sliding spring-controlled catch-pawl on said carrier, adapted to be limited at different distances by contact with the key-levers, whereby the plate moves 105 to and is caught at different distances, substantially as herein described.

8. In an adding-machine, the combination of the rotatory spring-actuated plates C and D, movable in opposite directions and having 110 teeth upon their rims, the pivoted spring-controlled pawl-carrier having the holding-pawl engaging the teeth of plate C, and the sliding spring-controlled catch-pawl engaging said teeth and limited at different distances, the keys and key-levers for operating said pawl-carrier and limiting the sliding pawl, the second pivoted spring-controlled pawl-carrier having a holding-pawl and a catch-pawl for controlling plate D, and the 120 key and key-lever for operating said second pawl-carrier, substantially as herein described.

9. In an adding-machine, the combination of the oppositely-rotating plates C and D, the 125 former having the series of numbers and the latter a sight-aperture, the spiral groove on the face of plate C, and the second sight-aperture in plate D, with spring-pointer having an edge traveling in the spiral groove of plate C, substantially as herein described. 130

10. In an adding-machine, the combination

4
of the oppositely-rotating plates C and D, the rotating front plate O, carrying numbers, a fixed sight-indicator for said plate, and a connection whereby the opposite movements of plates C and D are transmitted to rotate plate O in a single direction, substantially as herein described.

5
10
15
11. In an adding-machine, the combination of the oppositely-rotating plates C and D, a set of keys and connections for effecting the movement of plate C to different distances, and a single key for effecting the movement of plate D to a given distance, a front plate O, carrying numbers, a fixed sight-indicator for said plate, and a connection between plates C and D and plate O, whereby the opposite movements of the former are trans-

mitted to rotate the latter in a single direction, substantially as herein described.

12. In an adding-machine, the combination 20 of the oppositely-rotating plates C and D, the spring-actuated rotating front plate O, carrying numbers, a fixed sight-indicator for said plate, and the string wound about plates O and C in opposite directions and connected 25 with plate D by a slip-bearing, such as the roller *g*, substantially as herein described.

In witness whereof I have hereunto set my hand.

ARTHUR E. SHATTUCK.

Witnesses:

S. H. NOURSE,
H. C. LEE.